



DD-GOLD ET2

TUMBLE

DRYERS

DD-11 / 14 / 16



### EASY TOUCH 2

7" touch screen user friendly and programmable ET2  
USB Connection. PC software free of charge for  
programming, traceability, data analysis...  
Videos on display (ads, instructions, etc.)  
37 languages



### OUTSTANDING FEATURES

Reversing drum action as standard  
Stainless steel drum as standard  
Frequency inverter as standard



### EFFICIENCY

CARE DRY - Intelligent humidity control. With new  
drum inlet temperature control.  
AIR RE-CYCLE - Efficient air recirculation system  
INSULATED PANELS - Complete air-flow circuit  
Double door glass  
OPTIMAL FLOW - New optimized system of mixed  
airflow  
Big fluff filter



### VERSATILITY

Make to order - customisation  
WET CLEANING



### CONNECTIVITY

Remote technical service  
Management of laundries:



### ERGONOMICS

Drawer as fluff filter, made of stainless steel  
Biggest door diameters  
Opening sense of door adjustable on site



### MAINTENANCE

Hinged panel: easy and ergonomic access  
Technical menu: statistics, alarm, autotest, data  
recovery for technicians and maintenance



### OTHERS

Grey skinplate outer casing, stainless steel look  
Transmission by direct drive  
SPRINKLER - Integrated Fire Extinguishing System  
SOFT DRY - new drum with stamped holes  
COOL DOWN - anti-wrinkle at the end of the cycle  
Electric, gas and steam heating  
CE approved



## OPTIONS

- New perfumes dosing / vaporizing system
- Printer
- Danube Online IoT communication
- Tropicalized model
- Stainless steel outer casing
- Stainless steel front panel
- Stainless steel battery
- Low pressure steam battery
- Reverse door opening
- Fluff filter with grid 0,6 or 1,2 mm (standard is 0,3 mm)
- Rear panel with external air inlet + filter



Intertek



Intertek

TECHNICAL DATA	UNIT.	DD-11 GOLD ET2	DD-14 GOLD ET2	DD-16 GOLD ET2			
<b>CAPACITY</b>							
Capacity 1/18	Kg	12	15	18			
Capacity 1/20	Kg	11	13,5	17			
Hourly Output GOLD*	Kg/h	24-21	36-32	37-33			
Evaporation capacity GOLD*	l/h	15	15,6	16,3			
<b>DRUM</b>							
Ø Drum	mm	750	750	750			
Ø Door (load hole)	mm	574	574	574			
Door center height	mm	976	976	976			
Load hole bottom height	mm	689	689	689			
Drum length	mm	475	610	746			
Drum volume	l	210	270	330			
<b>POWER</b>							
Drum motor power	Kw	0,37	0,37	0,37			
Fan motor power GOLD	Kw	0,55	0,55	0,55			
Electric heating power ALL RANGES	Kw	12	18	18			
Total electric power (elec.model) GOLD	Kw	12,97	18,97	18,97			
Gas heating power ALL RANGES	Kw	20,51	20,51	20,51			
Total electric power (gas model) GOLD	Kw	0,97	0,97	0,97			
Steam heating power ALL RANGES	Kw	30	30	30			
Total electric power (steam model) GOLD	Kw	0,97	0,97	0,97			
<b>CONNECTIONS</b>							
		ELECTRICAL	STEAM / GAS	ELECTRICAL	STEAM / GAS	ELECTRICAL	STEAM / GAS
Tension 230V - I + N + T	Nº x mm2 / A	3 x 25 / 63A	3 x 1,5 / 20A	-	3 x 1,5 / 20A	-	3 x 1,5 / 20A
Tension 230V - III + T	Nº x mm2 / A	4 x 10 / 40A	3 x 1,5 / 20A	4 x 16 / 63A	3 x 1,5 / 20A	4 x 16 / 63A	3 x 1,5 / 20A
Tension 400V - III + N + T	Nº x mm2 / A	5 x 4 / 25A	3 x 1,5 / 20A	5 x 10 / 32A	3 x 1,5 / 20A	5 x 10 / 32A	3 x 1,5 / 20A
Ø Gas inlet	BSP	1/2"		1/2"		1/2"	
Ø Steam inlet	BSP	3/4"		3/4"		3/4"	
Ø Condensed (Steam models)	BSP	3/4"		3/4"		3/4"	
<b>DIMENSIONS / PACKING DIMENSIONS</b>							
Net Width / Gross Width	mm	785 / 865		785 / 865		785 / 865	
Net Depth / Gross Depth	mm	855 / 940		989 / 1.074		1.125 / 1.210	
Net Height / Gross Height	mm	1.694 / 1.840		1.694 / 1.840		1.694 / 1.840	
Height without heating battery	mm	-		-		-	
Net weight / Gross weight	Kg	172 / 180		180 / 190		187 / 200	
<b>OTHERS</b>							
Max airflow GOLD	m3/h	1.200		1.200		1.200	
Ø Fume exhaust	mm	200		200		200	
Sound level GOLD	dB	64		64		64	

\* It may vary depending on the type of heating, filter cleanliness or extraction type.

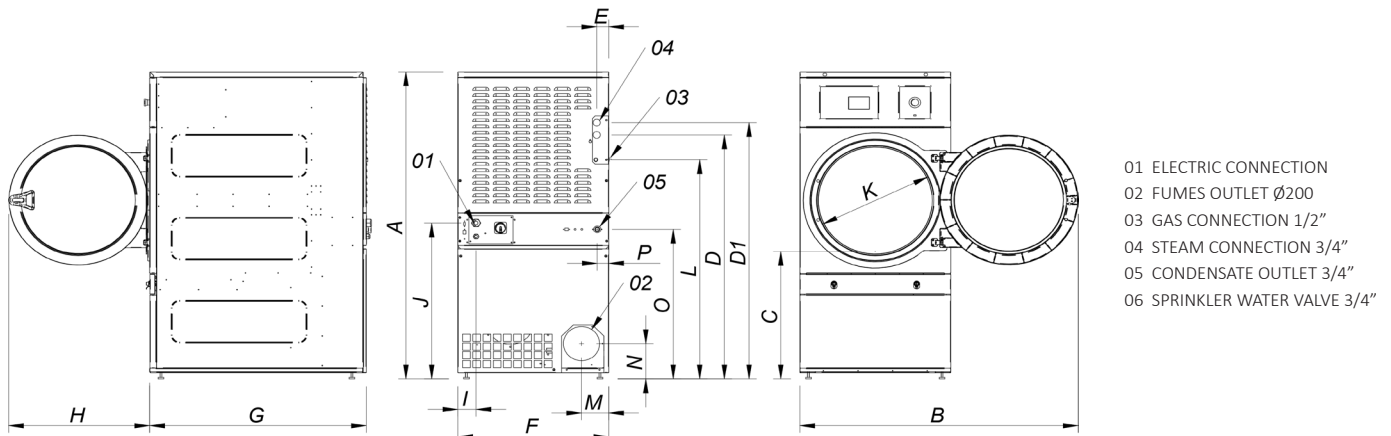

	A	B	C	D	D1	E	F	G	H	I	J	K	L	M	N	O	P
DD-11	1694	1447	689	1354	1422	68	785	855	735	95	870	575	1226	133	180	830	65
DD-14	1694	1447	689	1354	1422	68	785	989	735	95	870	575	1226	133	180	830	65
DD-16	1694	1447	689	1354	1422	68	785	1125	735	95	870	575	1226	133	180	830	65